

JUSTIN KASE

Manufactured By: KENDALL HOWARD 

Instructions



 Information Support Concepts, INC
Leading Information Technology Products Since 1987 

ServerRackOptions.com
800-458-6255

What's included...

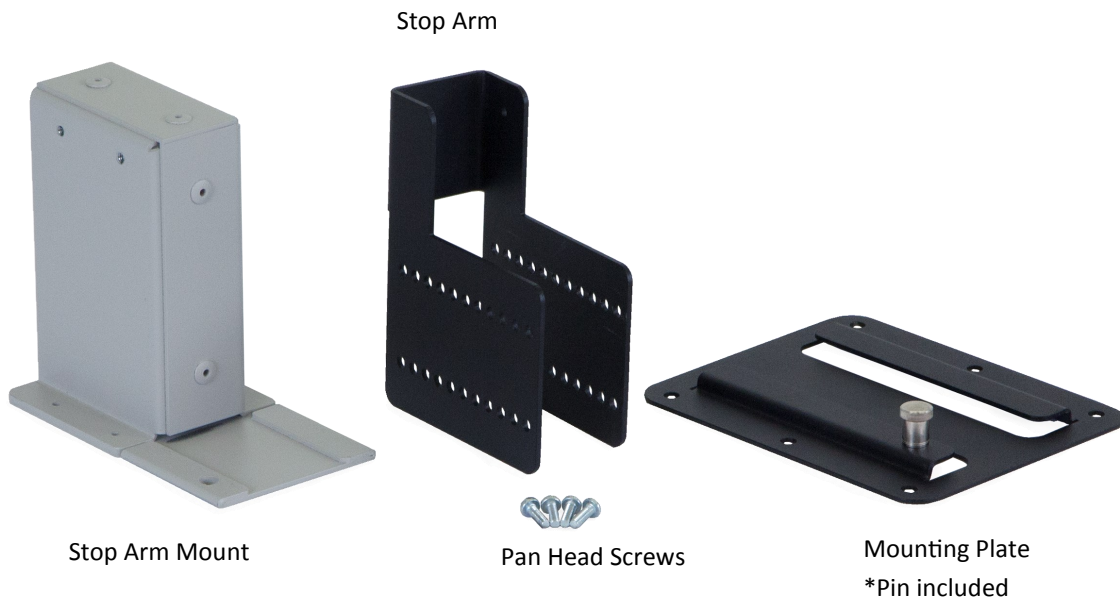

Step 1: While holding up the mounting plate and a level, mark the location of the mounting holes on the door. Be sure during mounting that the pin is in the correct location to lock into the stop arm mount when secured on the door. Use a 7/32" drill bit that is long enough to go all the way through the door. Keep the drill as level as possible while drilling the holes. Note: It is recommended the device be mounted within 12" of the door handle.

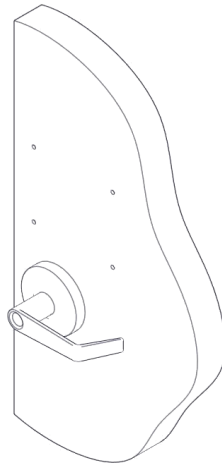

DISCLAIMER: Dominate Safety endeavors to make this manual accurate and complete. However, Dominate Safety makes no representations or warranties of any kind, expressed or implied, about whether the use of products contained herein would infringe any rights or the correctness, accuracy or reliability of the information contained herein or that said information covers all details, conditions or variations. The information herein does not provide for every possible contingency in connection with the installation or use of the product(s). The information contained in this document is subject to change without notice or obligation. Dominate Safety assumes no responsibility for the accuracy, completeness or reliability of the information contained in this document. Any reliance placed on the information is therefore strictly at your own risk.

Step 2: Secure the mounting plate using #10 bolts and nuts. The bolt head can not accept any type of drill bit. For wood doors, a carriage bolt is recommended. Although securing the outer four holes to the door are critical for proper mounting, the middle two holes are recommended for best results. Note: Hardware is not provided.

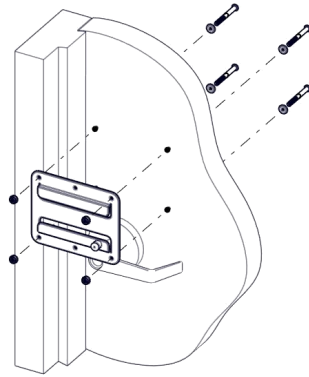

Step 3: To adjust the height of the door stop arm, use a Philips head screw driver. Slide the stop arm to fit as close to the frame as possible and fasten all 4 pan head screws.

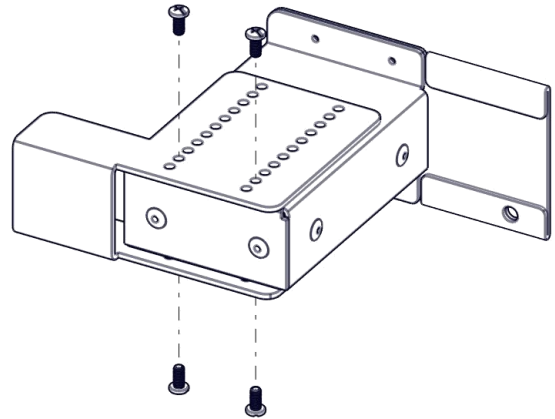

Step 4: Test the fitting of the device by sliding the door stop arm onto the door plate. To do this, lift the pin attached to the mounting plate and slide the door arm stop between the off-set materials on the mounting plate. The pin will lock into place once the device is slid into place properly.

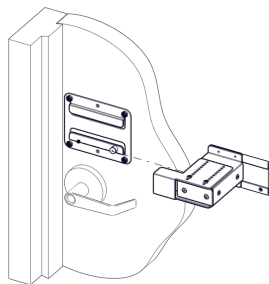

Try to move the device back and forth to insure it is locked into place.

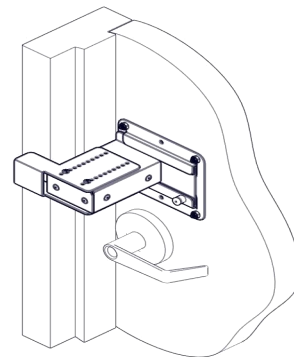

DISCLAIMER: Dominate Safety endeavors to make this manual accurate and complete. However, Dominate Safety makes no representations or warranties of any kind, expressed or implied, about whether the use of products contained herein would infringe any rights or the correctness, accuracy or reliability of the information contained herein or that said information covers all details, conditions or variations. The information herein does not provide for every possible contingency in connection with the installation or use of the product(s). The information contained in this document is subject to change without notice or obligation. Dominate Safety assumes no responsibility for the accuracy, completeness or reliability of the information contained in this document. Any reliance placed on the information is therefore strictly at your own risk.