

Assembly Instructions

2-Piece & 4-Piece Conversion Kits

Part Numbers:

1927-3-002-00

1927-3-004-00

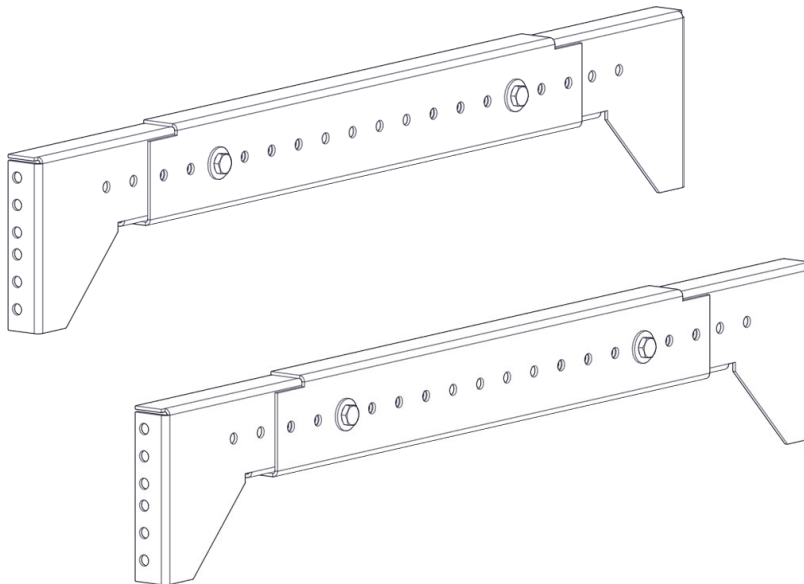

Information Support Concepts
2384 Highway 287 N.
Suite 208
Mansfield, TX 76063-9207

800-458-6255 U.S. Only
Fax (817) 842-9099
Local (817) 842-9090

www.serverrackoptions.com

Tools needed:

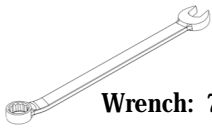

Wrench: 7/16

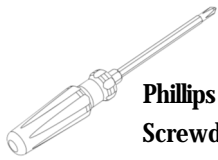

Phillips Head
Screwdriver

What's in the box:

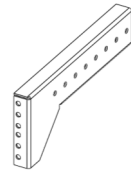

QTY 4 (4-Piece)
QTY 2 (2-Piece)
Left Arm Brackets

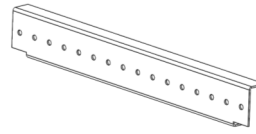

QTY 4 (4-Piece)
QTY 2 (2-Piece)
Center Arm Brackets

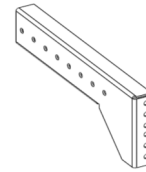

QTY 4 (4-Piece)
QTY 2 (2-Piece)
Arm Brackets



QTY 16 (2-Piece) 32 (4-Piece)
Flat Washers



QTY 8 (2-Piece) 16 (4-Piece)
7/16 Hex Nuts



QTY 8 (2-Piece) 16 (4-Piece)
7/16 Hex Bolts

Step 1:

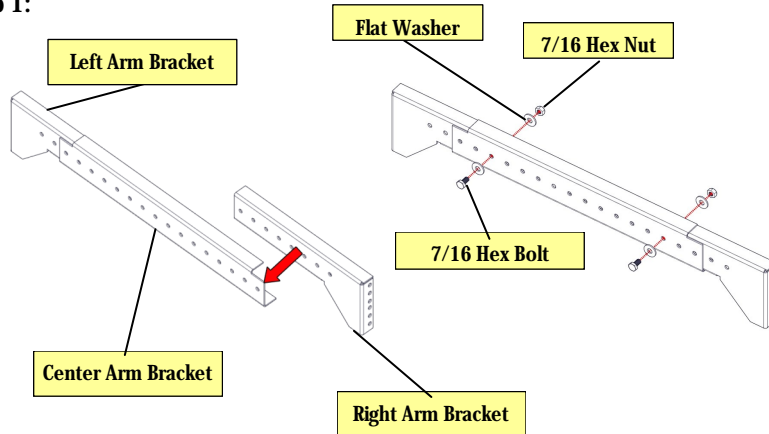

Insert the Left and Right Arm Brackets into the Center Arm Bracket as shown and secure with included 7/16 hardware. Make sure you set them for your desired depth. Follow this step for each of the arm assemblies.

* Note - Be sure the Center Arm is centered so the weight is evenly distributed.

Step 2:

Mount one arm at a time to each rack using the correct screws for your rack type (not included), placing them at the upper corners (2-Piece Conversion Kit) or upper and lower corners (4-Piece Conversion Kit). The more screws that you use to mount the arms to your 2-post racks, the stronger the overall rack will be. Each arm allows for six screws per side.

Wall Mount Installation: For wall mount application, install the arms as shown to the right and attach the opposite end to the wall. We recommend using a piece of plywood or similar material to attach the arms too. Then attach the plywood to the wall using anchor bolts directly into the wall studs.

