



Assembly Instructions

Advanced Classroom Training Tables

Part Numbers:

Folkstone:	Hard Rock Maple	Caramel Apple:	Serene Cherry:	African Mahogany:
5500-3-000-23	5500-3-001-23	5500-3-002-23	5500-3-003-23	5500-3-004-23
5500-3-000-33	5500-3-001-33	5500-3-002-33	5500-3-003-33	5500-3-004-33
5500-3-000-24	5500-3-001-24	5500-3-002-24	5500-3-003-24	5500-3-004-24
5500-3-000-34	5500-3-001-34	5500-3-002-34	5500-3-003-34	5500-3-004-34
5500-3-000-25	5500-3-001-25	5500-3-002-25	5500-3-003-25	5500-3-004-25
5500-3-000-35	5500-3-001-35	5500-3-002-35	5500-3-003-35	5500-3-004-35
5500-3-000-26	5500-3-001-26	5500-3-002-26	5500-3-003-26	5500-3-004-26
5500-3-000-36	5500-3-001-36	5500-3-002-36	5500-3-003-36	5500-3-004-36



Information Support Concepts
 2384 Highway 287 N.
 Suite 208
 Mansfield, TX 76063-9207

800-458-6255 U.S. Only
 Fax (817) 842-9099
 Local (817) 842-9090

www.serverrackoptions.com

Tools Needed:

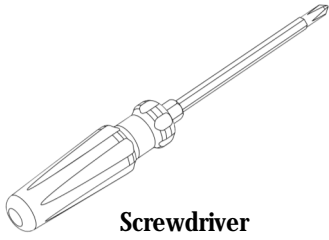

Screwdriver

What's Included:



QTY 1: Left Leg Assembly

QTY 1: Right Leg Assembly



QTY 1: Modesty Panel



QTY 1: Table Top



QTY 4: End Caps



QTY 1: Modesty Panel Grommet



QTY 4: Levelers



QTY 1: Surface Grommet



QTY 25: 1/4-20" Screws

Step 1:

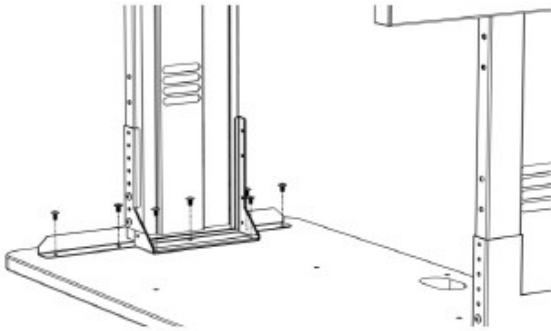

- A. Position table top with smooth surface facing down.
- B. Line up leg assemblies with pre-drilled hole pattern. (Note: Shorter side of legs face back of the table.)
- C. Fasten to table top with 1/4-20" screws.

*If installing the Cable Management Enclosure, leave out the back two screws in the legs.

Step 2:

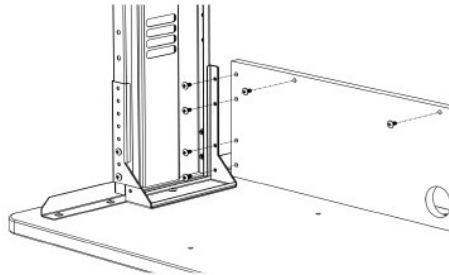

*If installing the Cable Management Enclosure, proceed to mount that to the modesty panel before assembling the panel to the training table.

- A. Attach modesty panel to the back edge of the right and left leg assemblies. (Ensure the grommet opening is closest to the work surface.)
- B. Fasten with 1/4-20" screws.

*If not installing the Cable Management Enclosure, fill in additional threaded holes in modesty panel with additional screws.

Step 3:

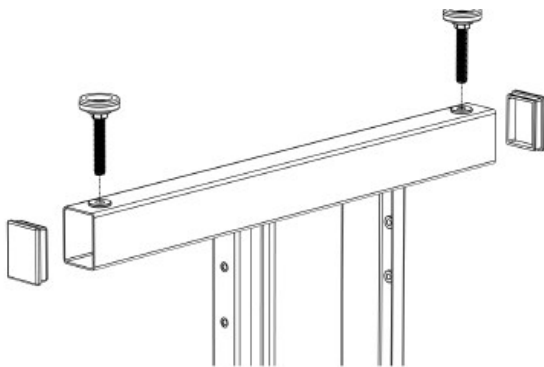

- A. Insert levelers into the threaded inserts in the bottom of the leg assemblies.
- B. Insert end caps into base of each leg.

Step 4:

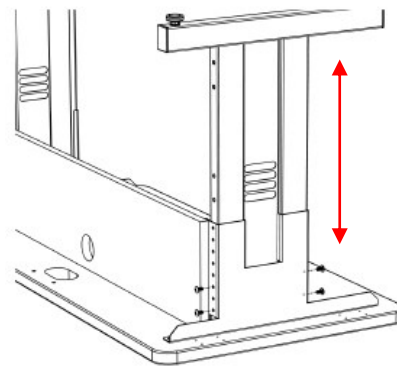

- A. Set the training table height on each leg assembly by unscrewing and sliding the leg to the desired position.
- B. Re-insert screws to secure.